

Straight Plate Chains

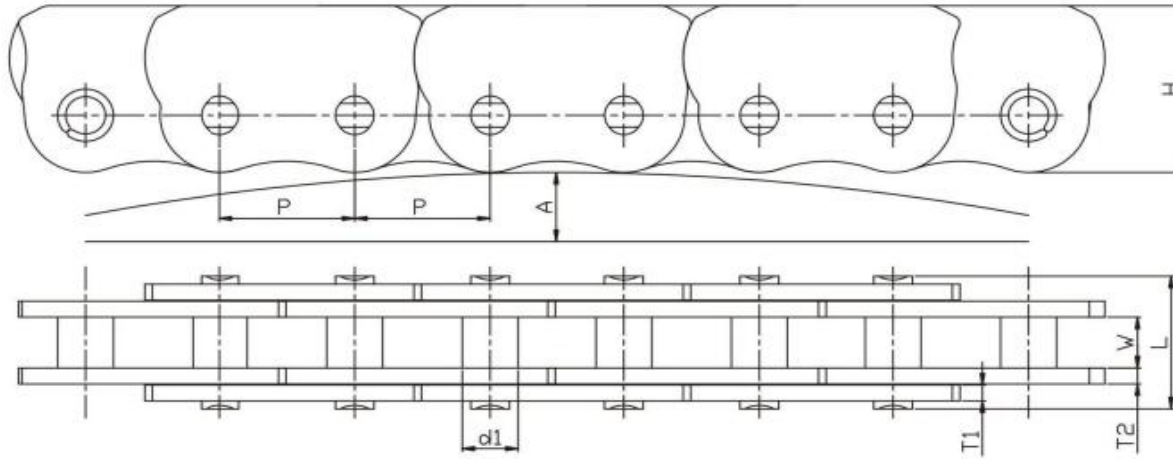

ZMIE Chain No.	Pitch	Inner width	Roller diameter	Pin length	Plate depth	Outer plate thickness	Inner plate thickness	Back bow	Breaking loading
	P	W(min)	D(max)	L(max)	H	T1	T2	A	Q(min)
	mm	mm	mm	mm	mm	mm	mm	mm	KN
K05BH	8.0	3.0	3.3	8.4	10.5	1.0	1.0	According to customer requirement	4.4

Straight Plate Chains

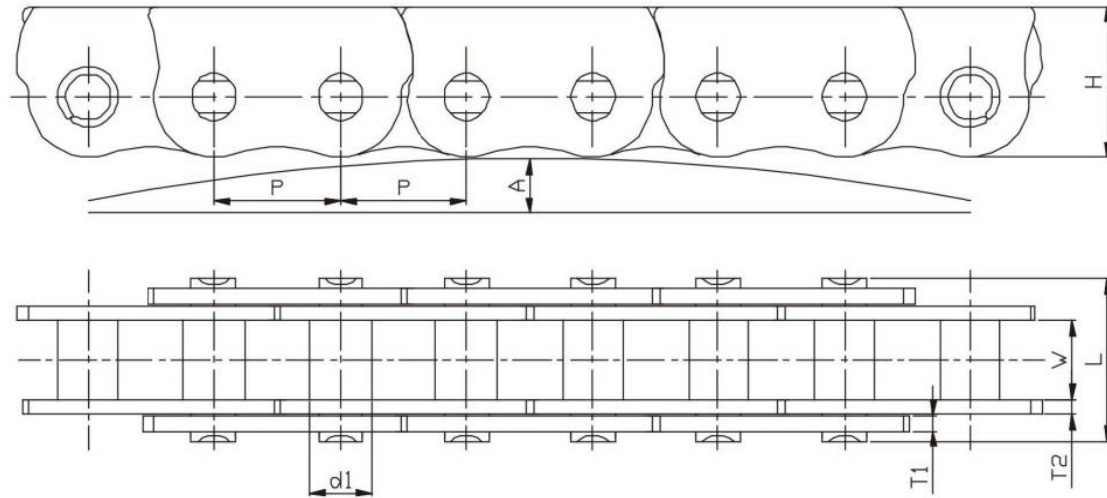

ZMIE Chain No.	Pitch	Inner width	Roller diameter	Pin length	Plate depth	Outer plate thickness	Inner plate thickness	Back bow	Breaking loading
	P	W(min)	D(max)	L(max)	H	T1	T2	A	Q(min)
	mm	mm	mm	mm	mm	mm	mm	mm	KN
K35	9.525	5.08	4.67	13.2	13.5	1.3	2.0	According to customer requirement	8.5
K35A	9.525	5.08	4.67	11.7	13.5	1.3	1.3		7.9
K35B	9.525	5.08	4.67	11.7	13.0	1.3	1.3		7.9
K35C	9.525	5.08	4.67	14.7	13.5	2.0	2.0		10.8
K35D	9.525	5.08	4.00	13.8	13.5	2.0	2.0		10.8
K35SS	9.525	5.08	4.67	13.2	13.5	1.3	2.0		5.1
K35ASS	9.525	5.08	4.67	11.7	13.5	1.3	1.3		4.7
K35BSS	9.525	5.08	4.67	11.7	13.0	1.3	1.3		4.7
K35CSS	9.525	5.08	4.67	14.7	13.5	2.0	2.0		6.5

Straight Plate Chains

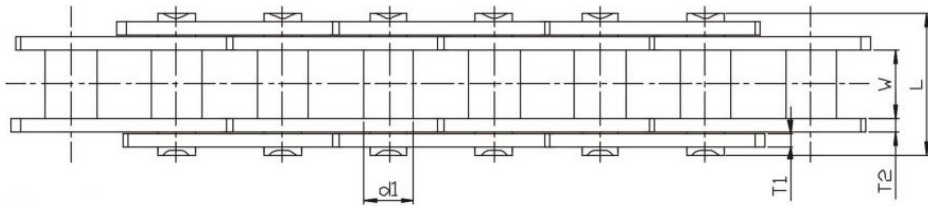
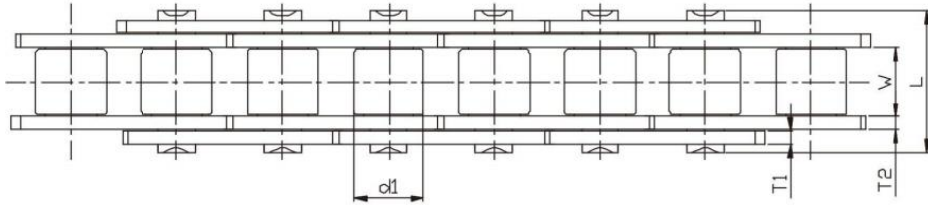
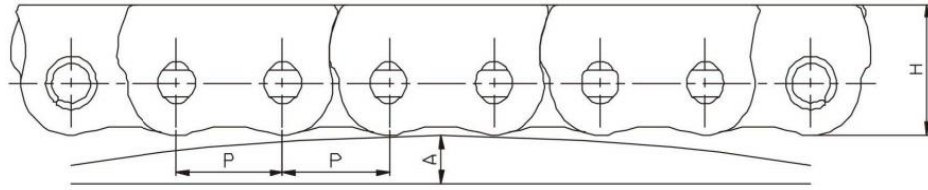

ZMIE Chain No.	Pitch	Inner width	Roller diameter	Pin length	Plate depth	Outer plate thickness	Inner plate thickness	Back bow	Breaking loading
	P	W(min)	D(max)	L(max)	H	T1	T2	A	Q(min)
	mm	mm	mm	mm	mm	mm	mm	mm	KN
K40	12.7	7.92	7.85	16.35	16.9	1.5	1.5	According to customer requirement	13.9
K40A	12.7	6.12	5.10	13.90	15.0	1.5	1.5		13.9
K08B	12.7	8.51	7.75	16.35	16.9	1.5	1.5		13.9
K08BA	12.7	8.51	5.30	16.20	16.9	2.0	2.0		18.2
K40H	12.7	7.92	7.85	18.35	16.9	2.0	2.0		18.2
K40SS	12.7	7.92	7.85	16.35	16.9	1.5	1.5		8.5
K08BSS	12.7	8.51	7.75	16.50	16.9	1.5	1.5		8.5

Bend Plate Chains

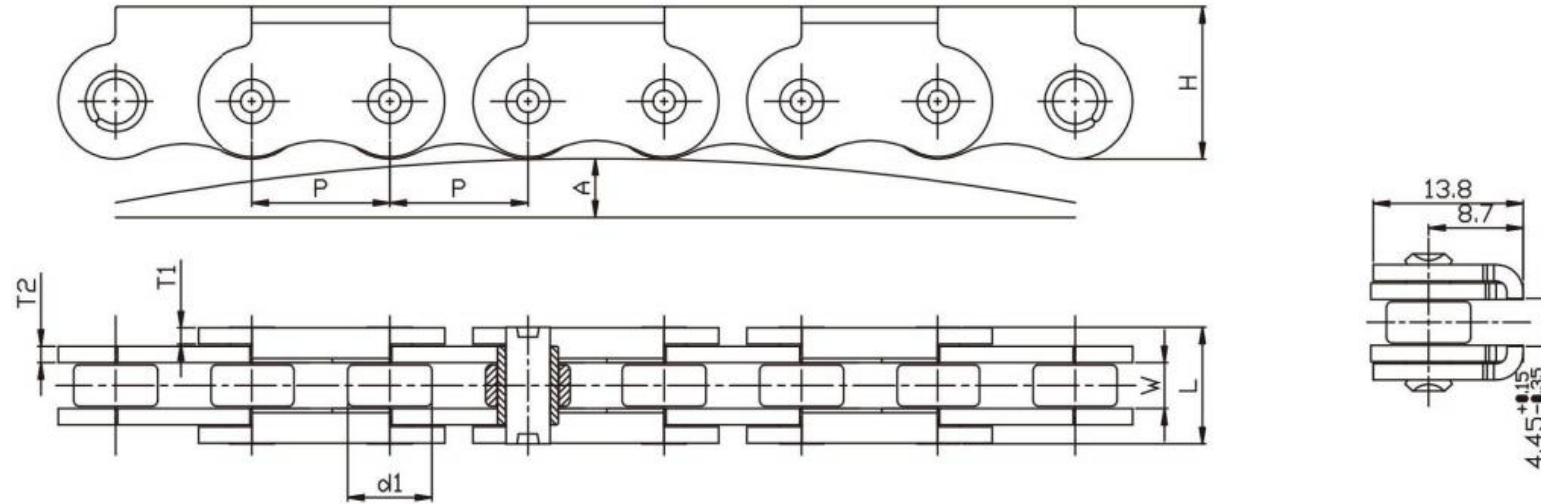

ZMIE Chain No.	Pitch	Inner width	Roller diameter	Pin length	Plate depth	Outer plate thickness	Inner plate thickness	Back bow	Breaking loading
	P	W(min)	D(max)	L(max)	H	T1	T2	A	Q(min)
	mm	mm	mm	mm	mm	mm	mm	mm	KN
K40DSS	12.7	7.75	4.10	11.00	14.0	1.5	1.5	According to customer requirement	8.5

Bend Plate Chains

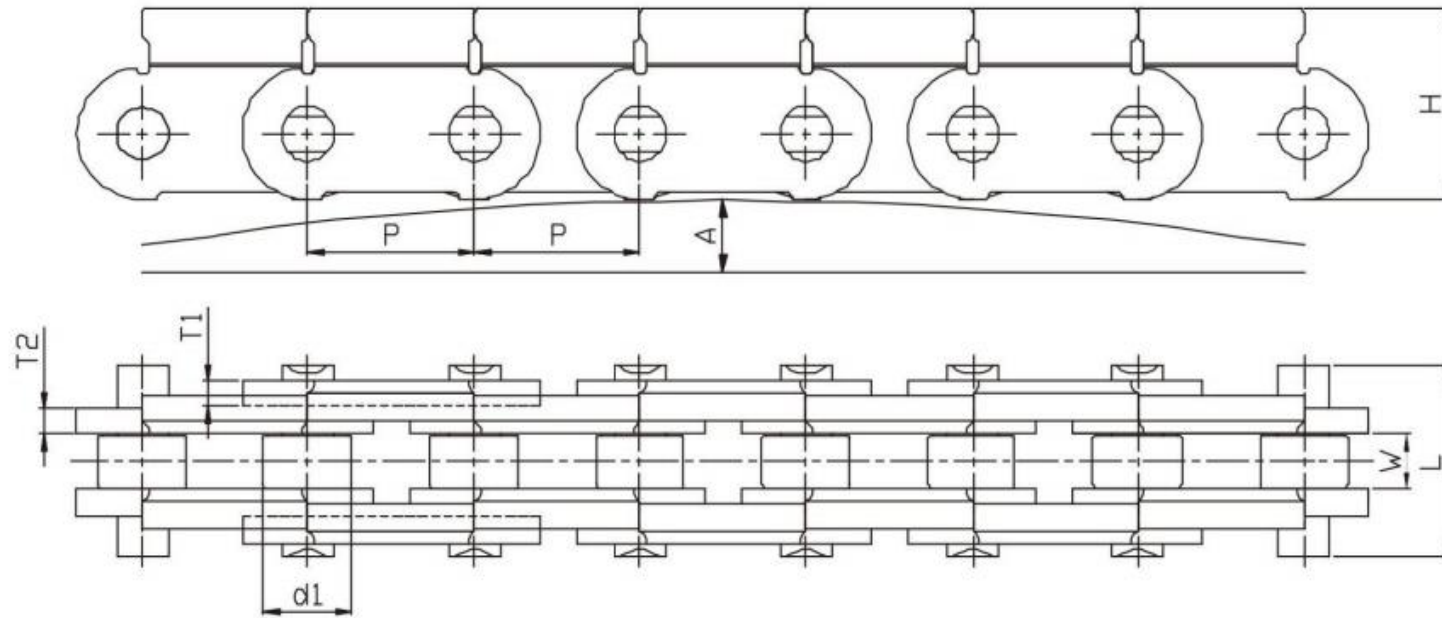

ZMIE Chain No.	Pitch	Inner width	Roller diameter	Pin length	Plate depth	Outer plate thickness	Inner plate thickness	Back bow	Breaking loading
	P	W(min)	D(max)	L(max)	H	T1	T2	A	Q(min)
	mm	mm	mm	mm	mm	mm	mm	mm	KN
K40CSS	12.7	6.75	4.00	14.70	14.6	2.0	2.0	According to customer requirement	10.0

Straight Plate Chains

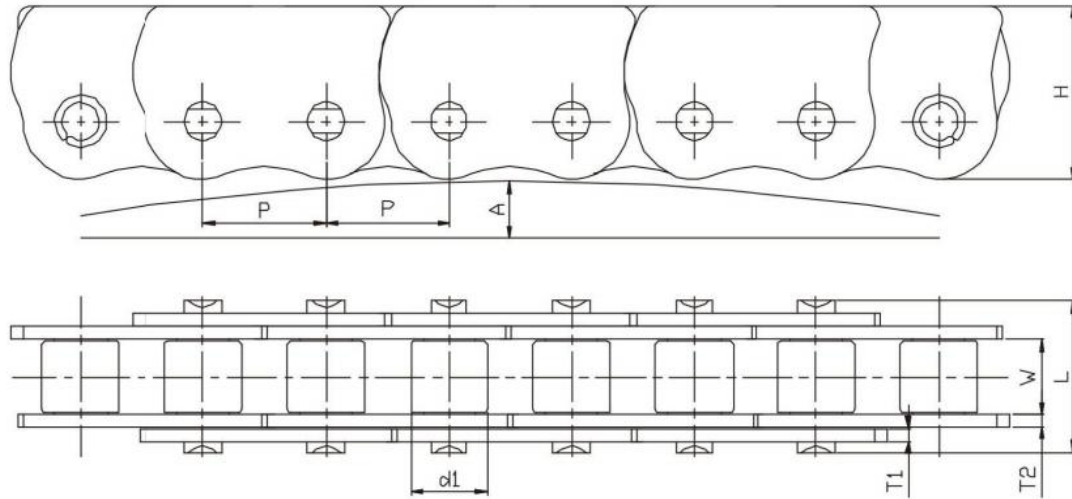

ZMIE Chain No.	Pitch	Inner width	Roller diameter	Pin length	Plate depth	Outer plate thickness	Inner plate thickness	Back bow	Breaking loading
	P	W(min)	D(max)	L(max)	H	T1	T2	A	Q(min)
	mm	mm	mm	mm	mm	mm	mm	mm	KN
K60	19.05	11.91	11.50	22.80	27.0	2.0	2.0	According to customer requirement	28.0